

Why must earthing and bonding be checked?

If you're having an alteration or addition made to your electrical installation, your electrician is required to first check, amongst other things, that the existing earthing and bonding arrangements are adequate. This is because the safety of any new work, however minor, will depend on those earthing and bonding arrangements (as does the safety of your existing installation).

What is earthing?

Metal parts of an electrical installation or appliance may become live if there's a fault. The purpose of earthing is to minimize the risk of electric shock should anyone touch those metal parts when a fault is present. This is achieved by providing a path for fault current to flow safely to earth, which also causes the protective device to disconnect the circuit, removing the danger.

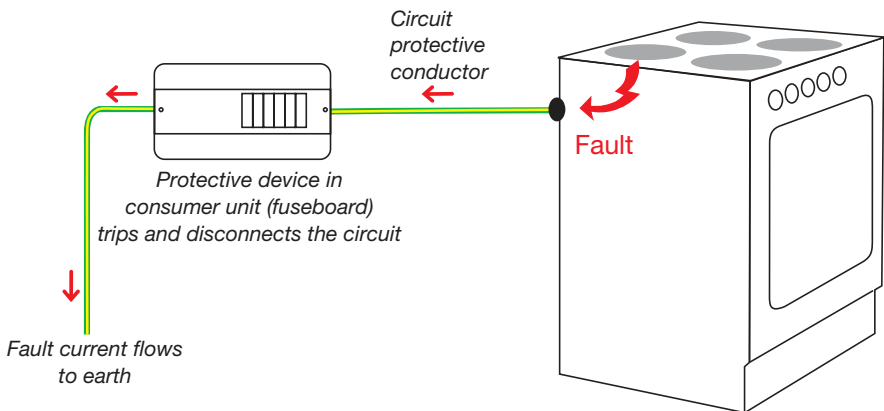

If the cooker develops a fault, the fault current flows safely to earth through the protective (earthing) conductor. This causes the protective device (fuse or circuit-breaker) in the consumer unit to disconnect the supply from the cooker, removing the risk of electric shock to anyone who touches it.

What is bonding?

This illustration shows: **MAIN PROTECTIVE BONDING**

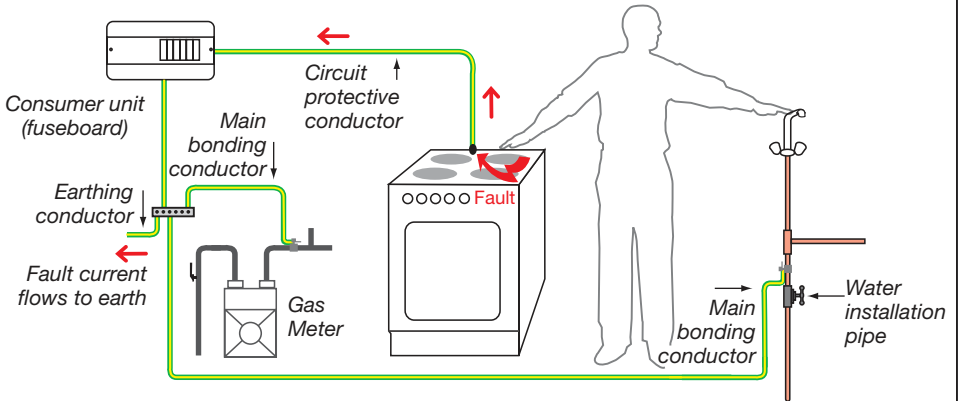

The purpose of bonding is to minimize the risk of electric shock to anyone who may be touching two separate conductive parts when a fault occurs somewhere in the supply or in the electrical installation (see above). This is achieved by connecting bonding conductors between particular points to minimize the voltage that may be created between them under fault conditions. Your electrician will advise you if the bonding arrangements in your premises need to be improved for safety reasons.

This illustration shows: **SUPPLEMENTARY BONDING**

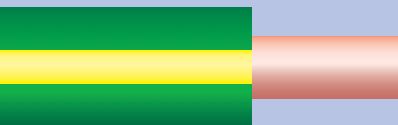
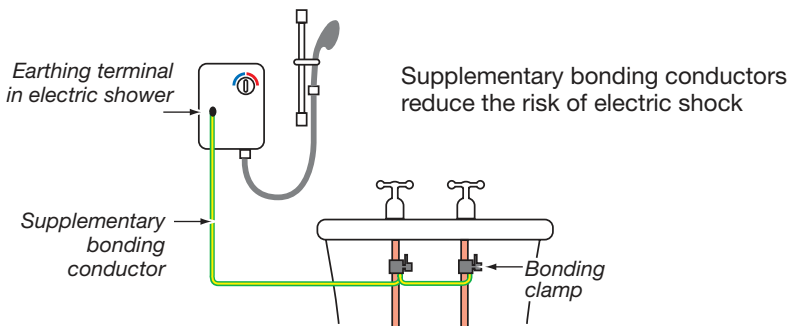

www.niceicgroup.com

NICEIC Group Ltd

Warwick House, Houghton Hall Park, Houghton Regis, Dunstable, LU5 5ZX.

For further copies of this guide or advice telephone 0870 0130382

or e-mail customerservice@niceic.com

m002/2 03/08